



FUZE WASH 575™

user manual

©2017 **ELATION PROFESSIONAL** all rights reserved. Information, specifications, diagrams, images, and instructions herein are subject to change without notice. ELATION PROFESSIONAL logo and identifying product names and numbers herein are trademarks of ELATION PROFESSIONAL. Copyright protection claimed includes all forms and matters of copyrightable materials and information now allowed by statutory or judicial law or hereinafter granted. Product names used in this document may be trademarks or registered trademarks of their respective companies and are hereby acknowledged. All non-ELATION brands and product names are trademarks or registered trademarks of their respective companies.

ELATION PROFESSIONAL and all affiliated companies hereby disclaim any and all liabilities for property, equipment, building, and electrical damages, injuries to any persons, and direct or indirect economic loss associated with the use or reliance of any information contained within this document, and/or as a result of the improper, unsafe, insufficient and negligent assembly, installation, rigging, and operation of this product.

Elation Professional USA | 6122 S. Eastern Ave. | Los Angeles, CA. 90040
323-582-3322 | 323-832-9142 fax | www.elationlighting.com | info@elationlighting.com

Elation Professional B.V. | Junostraat 2 | 6468 EW Kerkrade, The Netherlands
+31 45 546 85 66 | +31 45 546 85 96 fax | www.elationlighting.eu | info@elationlighting.eu

DOCUMENT VERSION

 Please check www.elationlighting.com for the latest revision/update of this manual.

Date	Document Version	Software Version \geq	DMX Channel Modes	Notes
06/23/17	1	1.02	9 / 11	Initial release.

CONTENTS

General Information	4
Warranty	6
Safety Instructions and Guidelines	7
Overview	9
Installation	10
Optional Snoot Installation	13
Fixture Menu	14
DMX Channel Functions And Values	18
Error Codes	20
Cleaning and Maintenance	21
Technical Specifications	22
Optional Accessories	25

GENERAL INFORMATION

INTRODUCTION

This fixture has been designed to perform reliably for years when the guidelines in this booklet are followed. Please read and understand the instructions in this manual carefully and thoroughly before attempting to operate this unit. These instructions contain important information regarding safety during use and maintenance.

UNPACKING

Every fixture has been thoroughly tested and has been shipped in perfect operating condition. Carefully check the shipping carton for damage that may have occurred during shipping. If the carton appears to be damaged, carefully inspect your unit for damage and be sure all accessories necessary to operate the unit have arrived intact. In the event damage has been found or parts are missing, please contact our customer support team for further instructions. Please do not return this unit to your dealer without first contacting customer support at the number listed below. Please do not discard the shipping carton in the trash. Please recycle whenever possible.

BOX CONTENTS

- (1) Omega Bracket
- (1) powerCON TRUE1 Cable

CUSTOMER SUPPORT

Elation Professional® provides a customer support line, to provide set up help and to answer any question should you encounter problems during your set up or initial operation. You may also visit us on the web at www.elationlighting.com for any comments or suggestions. For service related issue please contact Elation Professional®.

ELATION SERVICE USA - Monday - Friday 8:00am to 5:00pm PST

Voice: 323-582-3322

Fax: 323-832-9142

E-mail: support@elationlighting.com

ELATION SERVICE EUROPE - Monday - Friday 08:30 to 17:00 CET

Voice: +31 45 546 85 30

Fax: +31 45 546 85 96

E-mail: support@elationlighting.eu

WARRANTY RETURNS

All returned service items whether under warranty or not, must be freight pre-paid and accompany a return authorization (R.A.) number. The R.A. number must be clearly written on the outside of the return package. A brief description of the problem as well as the R.A. number must also be written down on a piece of paper and included in the shipping container. If the unit is under warranty, you must provide a copy of your proof of purchase invoice. Items returned without a R.A. number clearly marked on the outside of the package will be refused and returned at customer's expense. You may obtain a R.A. number by contacting customer support.



IMPORTANT NOTICE!

There are no user serviceable parts inside this unit. Do not attempt any repairs yourself; doing so will void your manufactures warranty. Damages resulting from modifications to this fixture and/or the disregard of safety and general user instructions found in this user manual void the manufactures warranty and are not subject to any warranty claims and/or repairs.

LIMITED WARRANTY

A. Elation Professional® hereby warrants, to the original purchaser, Elation Professional® products to be free of manufacturing defects in material and workmanship for a period of two years (730 days), and Elation Professional® product rechargeable batteries to be free of manufacturing defects in material and workmanship for a period of six months (180 days), from the original date of purchase. This warranty excludes discharge lamps and all product accessories. This warranty shall be valid only if the product is purchased within the United States of America, including possessions and territories. It is the owner's responsibility to establish the date and place of purchase by acceptable evidence, at the time service is sought.

B. For warranty service, send the product only to the Elation Professional® factory. All shipping charges must be pre-paid. If the requested repairs or service (including parts replacement) are within the terms of this warranty, Elation Professional® will pay return shipping charges only to a designated point within the United States. If any product is sent, it must be shipped in its original package and packaging material. No accessories should be shipped with the product. If any accessories are shipped with the product, Elation Professional® shall have no liability what so ever for loss and/or or damage to any such accessories, nor for the safe return thereof.

C. This warranty is void if the product serial number and/or labels are altered or removed; if the product is modified in any manner which Elation Professional® concludes, after inspection, affects the reliability of the product; if the product has been repaired or serviced by anyone other than the Elation Professional® factory unless prior written authorization was issued to purchaser by Elation Professional®; if the product is damaged because not properly maintained as set forth in the product instructions, guidelines and/or user manual.

D. This is not a service contract, and this warranty does not include any maintenance, cleaning or periodic check-up. During the periods as specified above, Elation Professional® will replace defective parts at its expense, and will absorb all expenses for warranty service and repair labor by reason of defects in material or workmanship. The sole responsibility of Elation Professional® under this warranty shall be limited to the repair of the product, or replacement thereof, including parts, at the sole discretion of Elation Professional®. All products covered by this warranty were manufactured after January 1, 1990, and bare identifying marks to that effect.

E. Elation Professional® reserves the right to make changes in design and/or performance improvements upon its products without any obligation to include these changes in any products theretofore manufactured.

F. No warranty, whether expressed or implied, is given or made with respect to any accessory supplied with the products described above. Except to the extent prohibited by applicable law, all implied warranties made by Elation Professional® in connection with this product, including warranties of merchantability or fitness, are limited in duration to the warranty periods set forth above. And no warranties, whether expressed or implied, including warranties of merchantability or fitness, shall apply to this product after said periods have expired. The consumer's and/or dealer's sole remedy shall be such repair or replacement as is expressly provided above; and under no circumstances shall Elation Professional® be liable for any loss and/or damage, direct and/or consequential, arising out of the use of, and/or the inability to use, this product.

G. This warranty is the only written warranty applicable to Elation Professional® products and supersedes all prior warranties and written descriptions of warranty terms and conditions heretofore published.

S A F E T Y I N S T R U C T I O N S A N D G U I D E L I N E S

This fixture is an extremely sophisticated piece of electronic equipment. To guarantee a smooth operation, it is important to follow all instructions and guidelines in this manual. The manufacturer of this device is not responsible for injury and/or damages resulting from the misuse of this fixture due to the disregard of the information printed in this manual. Only qualified and/or certified personnel should perform installation of this fixture and only the original rigging parts (omega brackets) included with this fixture should be used for installation. Any modifications to the fixture and/or the mounting hardware included will void the original manufacturer's warranty and increase the risk of damage and/or personal injury.



PROTECTION CLASS 1 - FIXTURE MUST BE PROPERLY GROUNDED

DO NOT PLUG FIXTURE INTO A DIMMER PACK!



NEVER OPEN THIS FIXTURE WHILE IN USE!

UNPLUG POWER BEFORE SERVICING FIXTURE!

NEVER TOUCH FIXTURE DURING OPERATION, AS IT MAY BE HOT!

KEEP FLAMMABLE MATERIALS AWAY FROM FIXTURE!



INDOOR / DRY LOCATIONS USE ONLY!

DO NOT EXPOSE FIXTURE TO RAIN AND MOISTURE!



NEVER LOOK DIRECTLY INTO THE LIGHT SOURCE!

RETINA INJURY RISK - MAY INDUCE BLINDNESS!

SENSITIVE PERSONS MAY SUFFER AN EPILEPTIC SHOCK!

SAFETY INSTRUCTIONS AND GUIDELINES

- **DO NOT TOUCH** the fixture housing during operation. Turn OFF the power and allow approximately 15 minutes for the fixture to cool down before serving.
- **DO NOT** shake fixture, avoid brute force when installing and/or operating fixture.
- **DO NOT** operate fixture if the power cord has become frayed, crimped and/or damaged. If the power cord is damaged, replace it immediately with a new one of similar power rating.
- **DO NOT** block any air ventilation slots. All fan and air inlets must remain clean and never blocked. Allow approx. 6" (15cm) between fixture and other devices or a wall for proper cooling.
- When installing fixture in a suspended environment, always use mounting hardware that is no less than M10 x 25 mm, and always install fixture with an appropriately rated safety cable.
- Always disconnect fixture from main power source before performing any type of service and/or cleaning procedure. Only handle the power cord by the plug end, never pull out the plug by tugging the wire portion of the cord.
- During the initial operation of this fixture, a light smoke or smell may emit from the interior of the fixture. This is a normal process and is caused by excess paint in the interior of the casing burning off from the heat associated with the lamp and will decrease gradually over time.
- Consistent operational breaks will ensure the fixture will function properly for many years to come.
- Use the original packaging and materials to transport the fixture in for service.

OVERVIEW

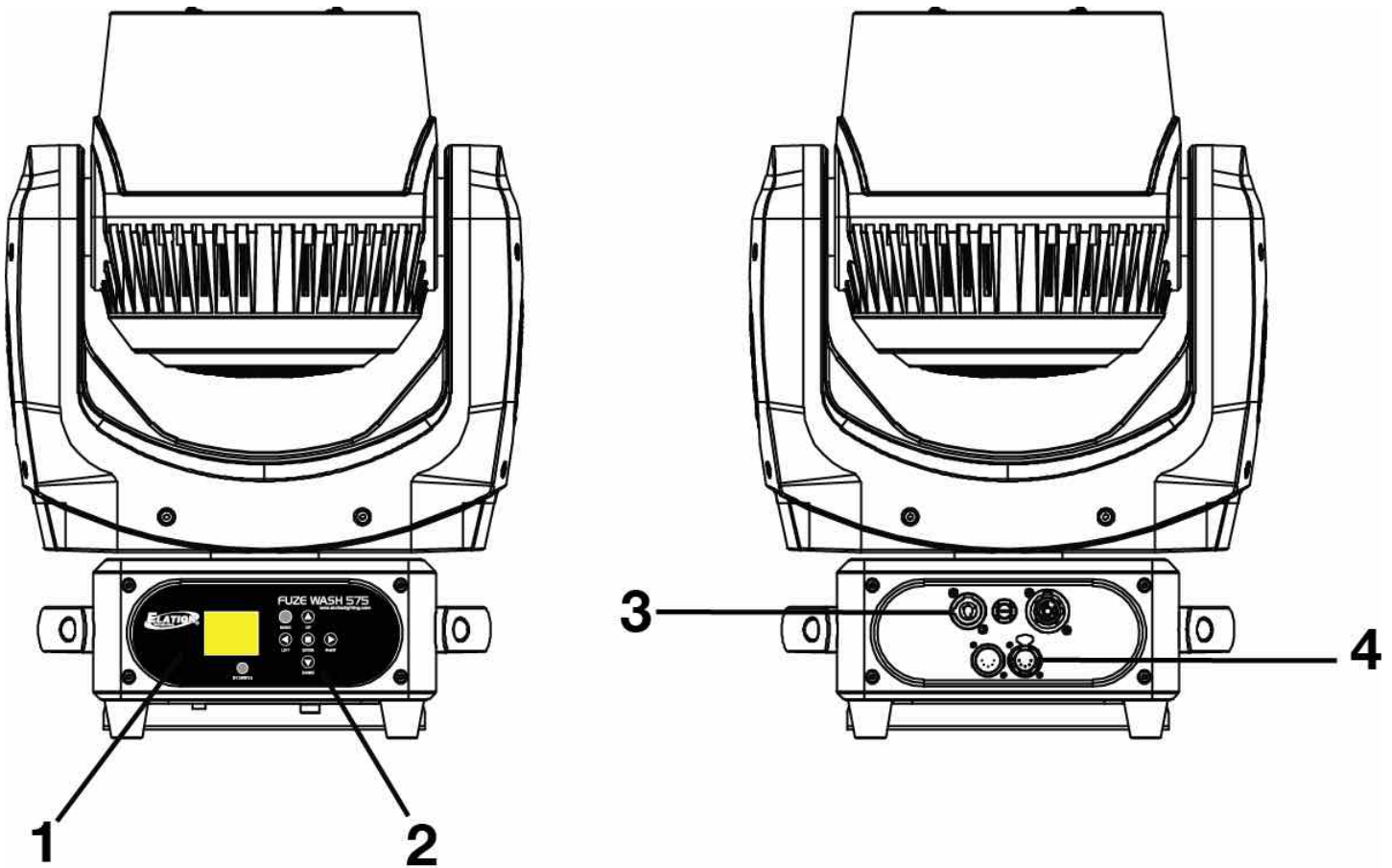

1. LCD Menu Display

2. MODE, UP, DOWN, LEFT, RIGHT, ENTER, DC Switch Buttons

3. powerCON TRUE1 IN/OUT, Fuse

4. 5pin DMX IN/OUT

INSTALLATION



FLAMMABLE MATERIAL WARNING

Keep fixture at least 5.0 ft (1.5m) away from any flammable materials, decorations, pyrotechnics, etc.



ELECTRICAL CONNECTIONS

A qualified electrician should be used for all electrical connections and/or installations.

CAUTIONS

- For added protection, mount the fixture in areas outside walking paths, seating areas, or in areas where unauthorized personnel might reach the fixture.
- Ambient operating temperature range for this fixture is **5° to 113°F. (-15° to 45°C)**
Do not use the fixture under or above this temperature.
- Before mounting the fixture to any surface, make sure the installation area can hold a minimum point load of 10 times the weight of the fixture.
- Fixture installation must always be secured with a secondary safety attachment, such as an appropriate safety cable.
- Never stand directly below the device when mounting, removing or servicing.

POWER LINKING

Max number of **FUZE WASH 575™** units power linked together:

4 units @120V | 8 units @240V



NOTE: USE CAUTION WHEN POWER LINKING OTHER FIXTURES TO FUZE WASH 575™!

POWER CONSUMPTION OF OTHER LIGHTING FIXTURES WILL VARY!

DO NOT EXCEED THE MAX AMP OUT RATING PRINTED ON THE CONNECTION PANEL!

CLAMP INSTALLATION

The fixture provides a unique mounting assembly (**Omega Bracket**) that attaches to the bottom of the base. (See the illustration below). When mounting this fixture to truss be sure to secure an appropriately rated clamp to the included **Omega Bracket** using a M10 screw fitted through the center hole of the **Omega Bracket**. Be sure to attach an appropriate **Safety Cable** (not included) to the fixture using the safety cable rigging point integrated in the base assembly.

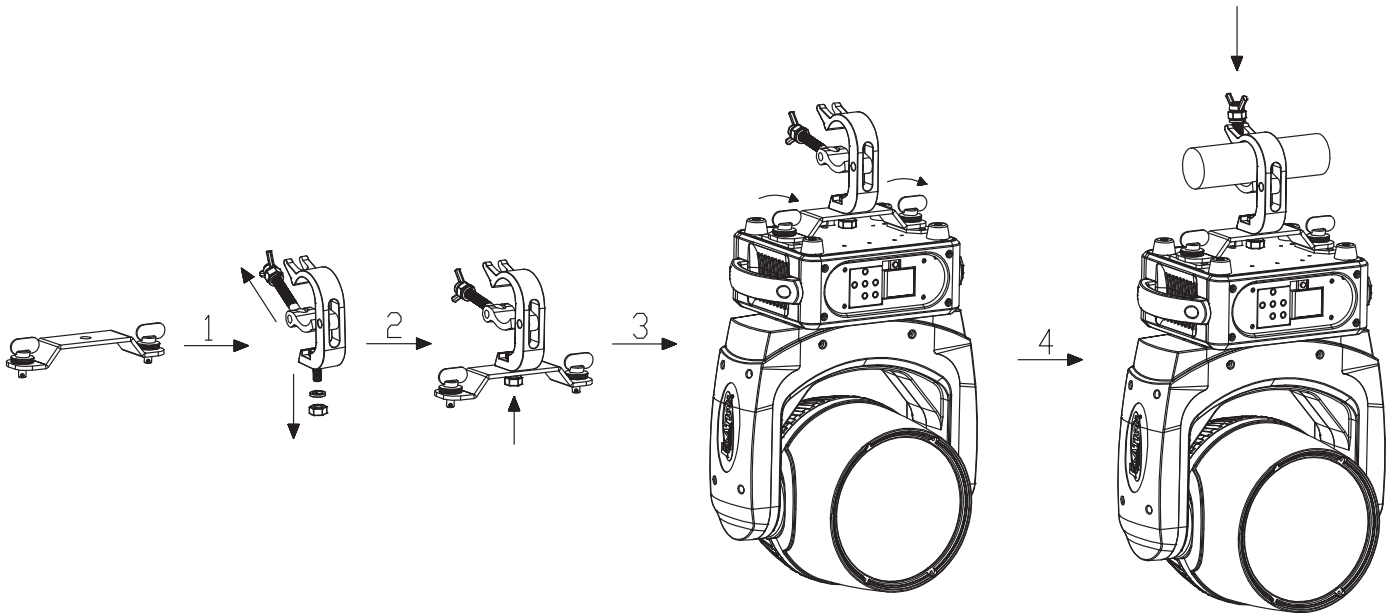

OMEGA BRACKET INSTALLATION

Insert the Omega Bracket into the matching holes on the bottom of the fixture. Secure the Omega Bracket to the fixture by turning each quick-lock fastener ¼ turn clockwise; making sure the fastener is completely locked.

SAFETY CABLE RIGGING POINT



SAFETY CABLE

ALWAYS ATTACH A SAFETY CABLE TO THE FIXTURE WHENEVER INSTALLING IN A SUSPENDED ENVIRONMENT TO ENSURE THE FIXTURE WILL NOT DROP IF CLAMP FAILS.

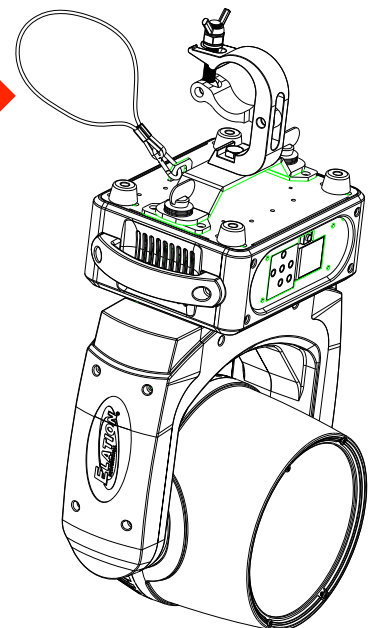

RIGGING

Overhead rigging requires extensive experience, including amongst others calculating working load limits, installation material being used, and periodic safety inspection of all installation material and the fixture. If you lack these qualifications, do not attempt the installation yourself. Improper installation can result in bodily injury. Fixture is fully operational in the specific mounting positions illustrated below.

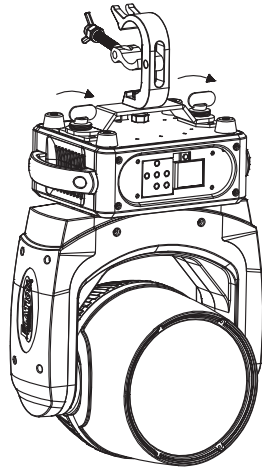

S A F E T Y C A B L E

ALWAYS ATTACH A SAFETY CABLE TO THE FIXTURE WHENEVER INSTALLING IN A SUSPENDED ENVIRONMENT TO ENSURE THE FIXTURE WILL NOT DROP IF CLAMP FAILS.

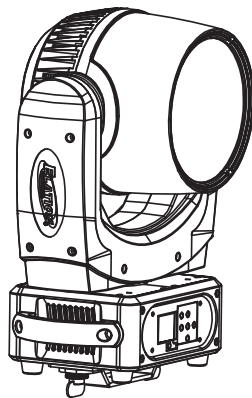
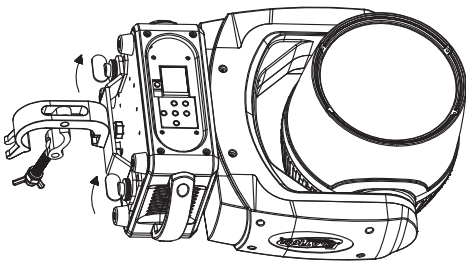

OPTIONAL SNOOT INSTALLATION

1. Place fixture on a flat surface and make sure it's powered OFF.
2. Insert Snoot into fixture head and secure using screws provided. (See image below)

Make sure not to over tighten screws to prevent any issues.

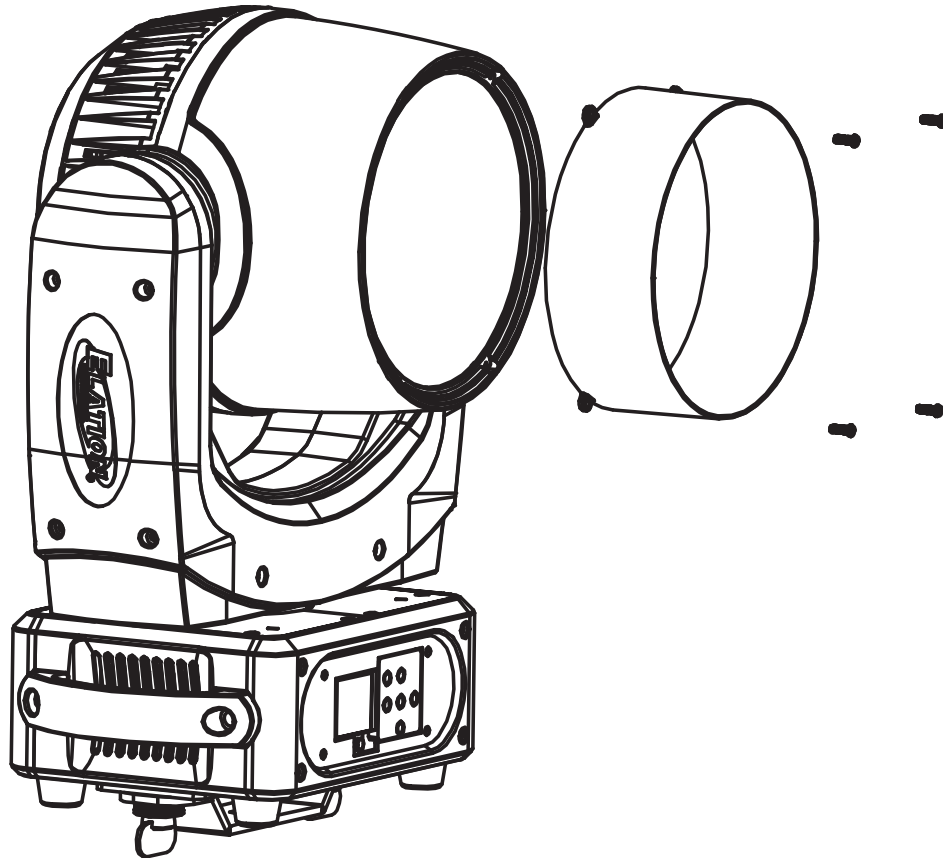

FIXTURE MENU

The fixture comes with an easy to navigate system menu. The control panel (see image below) located on the back of the fixture provides access to the main system menu and is where all necessary system adjustments are made to the fixture. During normal operation, pressing **MODE** button once will access the fixture's main menu. Once in the main menu you can navigate through the different functions and access the sub-menus with the **UP, DOWN, LEFT, and RIGHT** buttons. Once you reach a field that requires adjusting, press the **ENTER** button to activate that field and use the **UP** and **DOWN** buttons to adjust the field. Pressing the **ENTER** button once more will confirm your setting. You may exit the main menu at any time without making any adjustments by pressing the **MODE** button. To access the system menu when the fixture is not powered, press and hold the DC SWITCH button until the LCD screen illuminates, which will power the display screen using the internal battery.

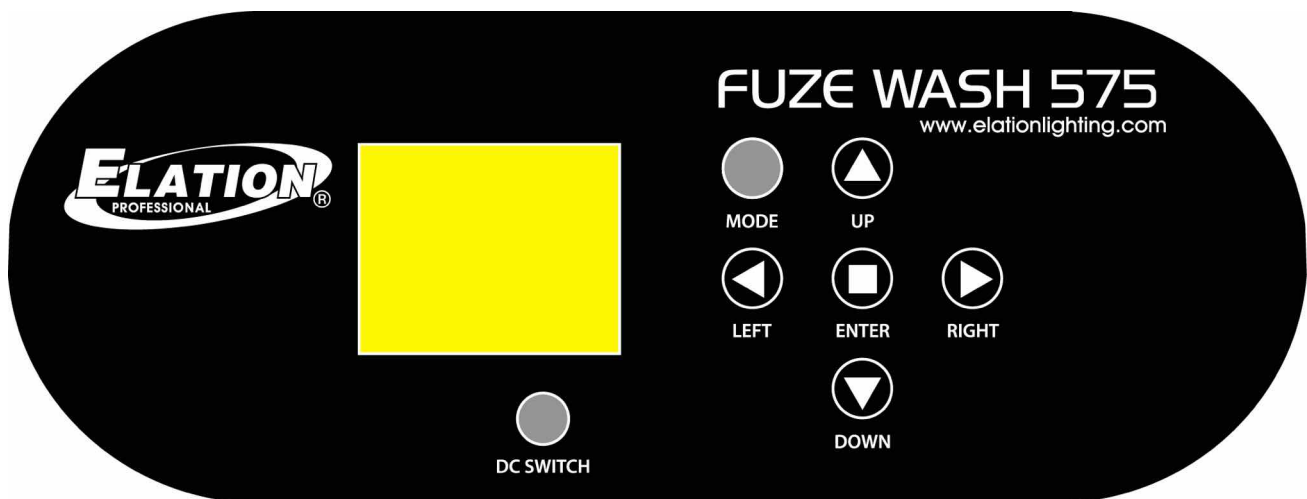

LCD CONTROL PANEL LOCKOUT

When the **Key Lock** menu is set to **ON**, the LCD display will turn OFF after 30 seconds and the (4) button Control Panel will be LOCKED. To unlock the (4) button LCD control panel, press and hold the **MODE** button.

INFORMATION DISPLAYED DURING INITIAL POWER ON

When the fixture is initially powered ON, the display shows the following information:



ELATION© FUZE WASH 575™
SYSTEM MENU

Features are subject to change without any prior written notice.

MAIN MENU	SUB MENU	OPTIONS / VALUES (Default Settings in BOLD)		DESCRIPTION	
Receive	Set DMX Address	001 ~ XXX		DMX Address Setting	
User Mode	User Mode	9CH 8-Bit, 11CH16-Bit User A, User B, User C		Set DMX Channel / User Mode	
	Edit A	Max. Chan : Dim Modes		Edit User Defined Channel Assignments	
	Edit B				
	Edit C				
Function	Status	Remote Add	ON/OFF	Set Fixture Address Via DMX Control	
		NoDMX Mode	Hold / Auto / Blackout	Function If NO DMX Detected	
		Pan Invert	ON / OFF	Pan Reverse Movement	
		TiltInvert	ON / OFF	Tilt Reverse Movement	
		Pan Degree	630/ 540	Pan Degree Select	
		Feedback	ON /OFF	Movement Feedback	
		Move. Spd	Speed 1 ~ 4	Movement Mode Select	
		Stand By	OFF, 01M~99M, 15M	Stand By Mode	
	Fan. Set	Head Fan	Auto , High, Low	Fan Speed Set	
	LCD. Set	Backlight	02~60m 05m	LCD Backlight Shut Off Time	
		FlipDisplay	ON / OFF	Flip/Reverse LCD Display 180°	
		Key Lock	ON / OFF	Control Front Panel Buttons Key Lock	
		Disp Flash	ON / OFF	Display flashes when NO DMX	
	Dim Curve	Standard , Stage, TV, Architectur, Theatre		Set Dimmer Curve Mode	
	Temp. C/F	Celsius/ Fahrenheit		Temperature Switch Between C° / F°	
	Init. Effect	Auto,Pro ~ Zoom		Initial Effect Position	
	Disp. Set	Chan. Value	ALL ~ Dim Modes		Value of each Channel Displayed
		Slave Set	Slave 1 , Slave 2, Slave 3		Set Slave Mode Preset
		Auto.Pro	Alone , Master		Set Auto Program Mode
DFSE	ON / OFF		Restore Factory Settings		
Information	Time. Info	Current	XXXX (Hours)	Fixture Run Time From Power ON	
		Total Time	XXXX (Hours)	Fixture Total Run Time	
		Last Clear	XXXX (Hours)	Clear Fixture Last Run Time	
		Timer PIN	PIN= 066	Enter PIN to Access Clear Last. Menu	
		Clear Last	ON / OFF	Reset Fixture Last Run Time	
	Temp. Info	Head Temp.	XXX C° / F °	Temperature in Fixture Head	
	Error Info	Error Record 1 ~ Error Record 10		Display 10 Recent Error Messages	
	Model. Info	Fuze Wash 575		Display Model Name	
Software Version (≥)	1U01:	V1.02		Software Versions (Greater than or Equal to)	
	2U01:	V1.02			
	3U01:	V1.02			

ELATION© FUZE WASH 575™ SYSTEM MENU					
Features are subject to change without any prior written notice.					
MAIN MENU	SUB MENU	OPTIONS / VALUES (Default Settings in BOLD)		DESCRIPTION	
Test	Reset. M	Pan&Tilt		Reset of Pan/Tilt Motors	
	Test. Chan			Test Functions	
	Panel. Ctrl			Fine Adjustments	
	Calibrate	Password	Password= 050	Calibration of Motors and LEDs	
Program	Select. Pro	Auto Pro Part1 = Program 1~9 (Program 1)		Select Programs To Be Run	
		Auto Pro Part2 = Program 1~9 (Program 2)			
		Auto Pro Part3 = Program 1~9 (Program 3)			
	Edit. Pro	Program 1	Program Test		Testing Program
		:	Step 01 =SCxxx		Program In Loop
		Program 9	Step 64 =SCxxx		Save and Exit
	Edit. Sce	Scene 001 ~ Scene 250	Pan,Tilt,.....		Save and Automatically Return
			--Fade Time-- --Scene Time--		Manual Scenes Edit
			Input By Outside		Stores Scenes via Ext DMX Console
	Sce. Input	XX~XX			Automatic Scenes Recorder

Function - Status - Remote Add

When ON, define the desired DMX address of fixture via an external controller.

1. Connect the fixture to the external controller and power ON.
2. Set the DMX value of **Channel 1** on the controller to **(7)**.
3. Set the DMX value of **Channel 2** on the controller to **(7)** or **(8)**.

When set to **(7)**, the DMX address can be set between **(1)** and **(255)**.

When set to **(8)**, the DMX address can be set between **(256)** and **(511)**.

4. Using **Channel 3** on the controller set the desired DMX address of the fixture.

Example 1:

If the desired DMX address is **57**, set **Channel 1** to a value of **(7)**, set **Channel 2** to a value of **(7)**, and then set **Channel 3** to a value of **(57)**.

Example 2:

If the desired DMX address is **420**, set **Channel 1** to a value of **(7)**, set **Channel 2** to a value of **(8)**, and then set **Channel 3** to a value of **(164)**. (256+164=420)

5. After setting **Channel 3** to the desired DMX address value, wait for approximately 20 seconds for the fixture to complete the address reset function.

Function - Dim Curve

The **Dim Curve** menu allows you to select one of the following preset dimming curves: **Standard**, **Stage**, **TV**, **Architectur**, or **Theatre**. (See below for more details)

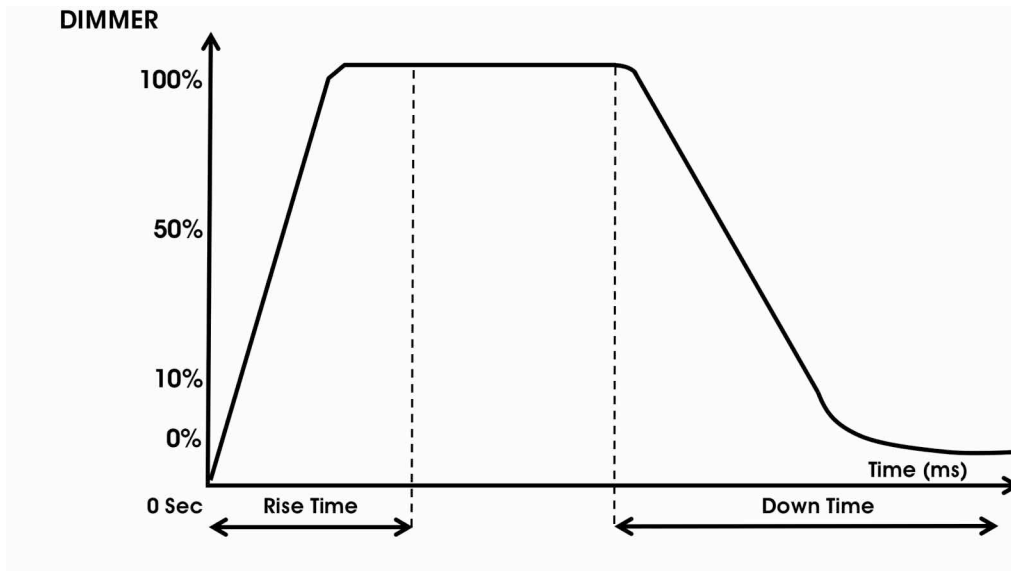

Dimming Curve Ramp Effect	0 sec Fade Time		1 sec Fade Time	
	Rise Time (ms)	Down Time (ms)	Rise Time (ms)	Down Time (ms)
Standard (default)	0	0	0	0
Stage	780	1100	1540	1660
TV	1180	1520	1860	1940
Architectural	1380	1730	2040	2120
Theatre	1580	1940	2230	2280

Test – Calibrate



ONLY QUALIFIED TECHNICIANS SHOULD PERFORM THIS FUNCTION

This function allows small adjustments to be made to the effect wheels to compensate for wear or in the event a sensor has been knocked slightly out of place. Because improper use of this function can result in undesired operation this function has been password protected. The password is **050** and must be entered each time the calibration menu function is entered. Because calibration is an extremely delicate procedure, instructions on performing this action are left out of this manual. For a first time calibrator, please contact our customer support team for step-by-step instructions.

DMX CHANNEL FUNCTIONS AND VALUES

ELATION© FUZE WASH 575™			
DMX Channel Values / Functions Version (11 DMX Channels)			
Supports Software Versions: ≥ 1.02			
Features are subject to change without any prior written notice.			
*Rotation direction (Clockwise or Counterclockwise) of effects depends on orientation of the fixture head and Pan/Tilt settings.			
MODE / CHANNEL		VALUE	FUNCTION
9CH 8-Bit	11CH16-Bit		
1	1		PAN MOVEMENT [8 BIT]
		0-255	PAN Movement [127]
	2		PAN FINE MOVEMENT [16 BIT]
		0-255	Fine Control of PAN Movement [127]
2	3		TILT MOVEMENT [8 BIT]
		0-255	TILT Movement [127]
	4		TILT MOVEMENT [16 BIT]
		0-255	Fine Control of TILT Movement [127]
3	5		DIMMER [8 BIT]
		0-255	0 to 100% [0]
4	6		DIMMER FINE [16 BIT]
		0-255	0 to 100% [0]
5	7		SHUTTER / STROBE
		0-31	LED OFF
		32-63	LED ON
		64-95	Strobe Effect SLOW to FAST
		96-127	LED ON
		128-159	Pulse Effect in Sequences
		160-191	LED ON
		192-223	Random Strobe Effect SLOW to FAST
224-255	LED ON [255]		
6	8		ZOOM
		0-255	Zoom 0% (11 Degrees) to 100% (40 Degrees) [127]
7	9		DIMMING CURVE MODES
		0-20	STANDARD [20]
		21-40	STAGE
		41-60	TV
		61-80	ARCHITECTURAL
		81-100	THEATRE
101-255	Default to Unit Setting		
8	10		PAN / TILT MOVEMENT SPEED
		0-225	MAX to MIN SPEED [0]
		226-235	Blackout By Movement
		236-255	NO FUNCTION

ELATION© FUZE WASH 575™			
DMX Channel Values / Functions Version (11 DMX Channels)			
Supports Software Versions: ≥ 1.02			
Features are subject to change without any prior written notice.			
*Rotation direction (Clockwise or Counterclockwise) of effects depends on orientation of the fixture head and Pan/Tilt settings.			
MODE / CHANNEL		VALUE	FUNCTION
9CH 8-Bit	11CH16-Bit		
9	11		LAMP ON/OFF, RESET, INTERNAL PROGRAMS
		0-79	Normal
		80-84	ALL Motor Reset
		85-89	ENABLE Auto Scene Mode
		90-99	SAVE New Auto Scene
		100-119	Internal Program 1 (scene1~8) or Saved Auto Scene (if used) NOTE: Each newly saved Auto Scene will over write previously saved Auto Scene
		120-139	Internal Program 2 (scene9~16)
		140-159	Internal Program 3 (scene17~24)
		160-179	Internal Program 4 (scene25~32)
		180-199	Internal Program 5 (scene33~40)
		200-219	Internal Program 6 (scene41~48)
		220-239	Internal Program 7 (scene49~56)
		240-255	NO FUNCTION [255]

AUTO SCENE MODE

This mode can be used to store a specific look for the fixture that can be saved as a scene. Once saved, the fixture will always recall this scene after losing power. This is useful for installations where power is turned off at night or at the end of use. Enabling this feature makes it easy for the fixture to regain its look/scene without having to adjust it from a controller/console.

1. Make sure all channels are set to zero (**0**) and fixture is in the desired user mode.
2. Depending on User Mode selected, set **channel 9 or 11** to a DMX value of **85-89**.
3. Set desired fixture look by adjusting pan, tilt, dimmer, dimmer fine, strobe/shutter, and zoom channels accordingly.
4. Depending on User Mode selected, set **channel 9 or 11** to a DMX value of **90-99**.
5. After a few seconds, the fixture briefly strobe indicating the scene is now saved.
5. Depending on User Mode selected, set **channel 9 or 11** to a DMX value of **100-119**, to confirm the desired look/scene is correct. If not, repeat steps 1-4 again.

NOTE: Each time you save a new Auto Scene, it will over write the previously saved Auto Scene.

ERROR CODES

When power is applied, the unit will automatically enter a “**Motor Reset**” mode, which brings all the internal motors to a home position. If there is an internal problem with one or more of the motors, an error code (see below) will flash on the control display.

ERROR CODE	DESCRIPTION
TILT Er	The TILT movement is not located in the default position after the reset. This message will appear after a fixture reset if the magnetic-indexing circuit malfunctions (sensor failed or magnet is missing) or there is a motor failure (defective motor or defective motor IC drive on main PCB). This error may also be displayed if the head was blocked during a reset function
PAN Er	The PAN movement is not located in the default position after the reset. This message will appear after a fixture reset if the magnetic-indexing circuit malfunctions (sensor failed or magnet is missing) or there is a motor failure (defective motor or a defective motor IC drive on the main PCB). This error may also be displayed if the head/yoke was blocked during a reset function.
ZOOM Er	The ZOOM movement is not located in the default position after the reset. This message will appear after a fixture reset if the magnetic-indexing circuit malfunctions (sensor failed or magnet is missing) or there is a motor failure (defective motor or a defective motor IC drive on the main PCB). This error may also be displayed if the head/yoke was blocked during a reset function.

CLEANING AND MAINTENANCE



C A U T I O N

Disconnect power before cleaning or maintenance.

CLEANING

Frequent cleaning is recommended to insure proper function, optimized light output, and an extended life. The frequency of cleaning depends on the environment in which the fixture operates: damp, smoky or particularly dirty environments can cause greater accumulation of dirt on the fixture's optics.

- Clean the external lens surface at least every 20 days with a soft cloth to avoid dirt/debris accumulation.
- Never use alcohol, solvents, or ammonia based cleaners.

MAINTENANCE

Regular inspections are recommended to insure proper function and extended life. There are no user serviceable parts inside this fixture, please refer all other service issues to an authorized Elation service technician. Should you need any spare parts, please order genuine parts from your local Elation dealer.

Please refer to the following points during routine inspections:

- A detailed electric check by an approved electrical engineer every three months, to make sure the circuit contacts are in good condition and prevent overheating.
- Be sure all screws and fasteners are securely tightened at all times. Loose screws may fall out during normal operation resulting in damage or injury as larger parts could fall.
- Check for any deformations on the housing, color lenses, rigging hardware and rigging points (ceiling, suspension, trussing). Deformations in the housing could allow for dust to enter into the fixture. Damaged rigging points or unsecured rigging could cause the fixture to fall and seriously injure a person(s).
- Electric power supply cables must not show any damage, material fatigue or sediments. Never remove the ground prong from the power cable.

TECHNICAL SPECIFICATIONS

SOURCE

350W Cool White / Daylight COB LED
50,000 Hour Average LED Life*

*May vary depending on several factors including but not limited to:
Environmental Conditions, Power/Voltage, Usage Patterns (On-Off Cycling), Control, and Dimming.

EFFECTS

Motorized Zoom
Electronic Strobe
Variable Dimming Curve Modes

CONTROL / CONNECTIONS

(2) DMX Channel Modes (11 Total Channels)
(7) Button Touch Control Panel and LCD Menu Display
Smooth 16-Bit Pan and Tilt Movement
RDM (Remote Device Management)
5pin DMX and powerCON TRUE1 In/Out

SIZE / WEIGHT (with barn doors attached)

Length: 13.3" (337.7mm)
Width: 9.0" (228.8mm)
Vertical Height: 18.33" (465.7mm)
Weight: 27.0 lbs. (12.2kg)

ELECTRICAL / THERMAL

AC 100-250V - 50/60Hz
425W Max Power Consumption
5°F to 113°F (-15°C to 45°C)

APPROVALS / RATINGS

CE | IP30

Please Note: Specifications and improvements in the design of this unit and this manual are subject to change without any prior written notice.

DIMENSIONAL DRAWINGS

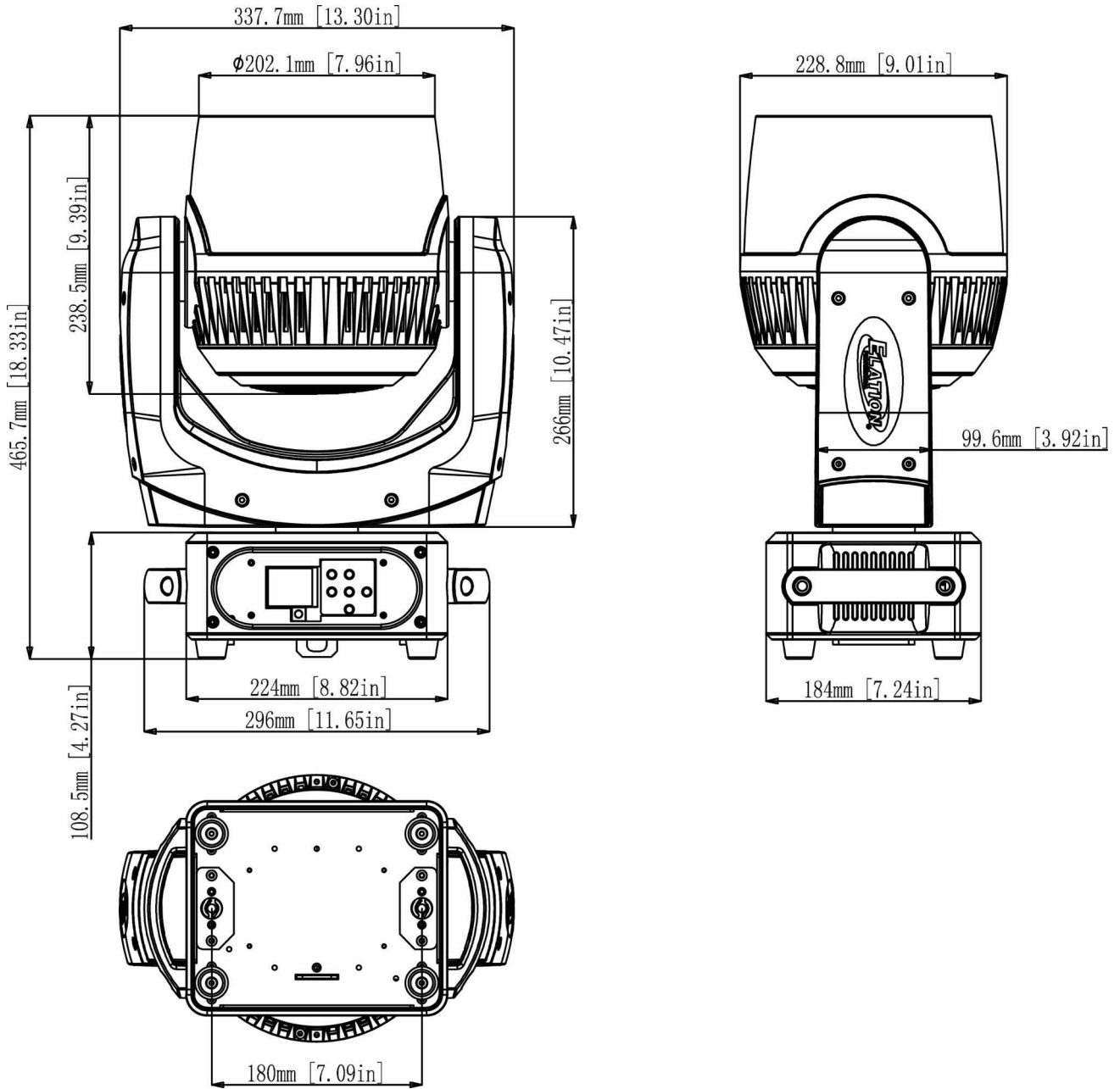

Please Note: Specifications and improvements in the design of this unit and this manual are subject to change without any prior written notice.

DIMENSIONAL DRAWINGS - Optional Snoot Installed

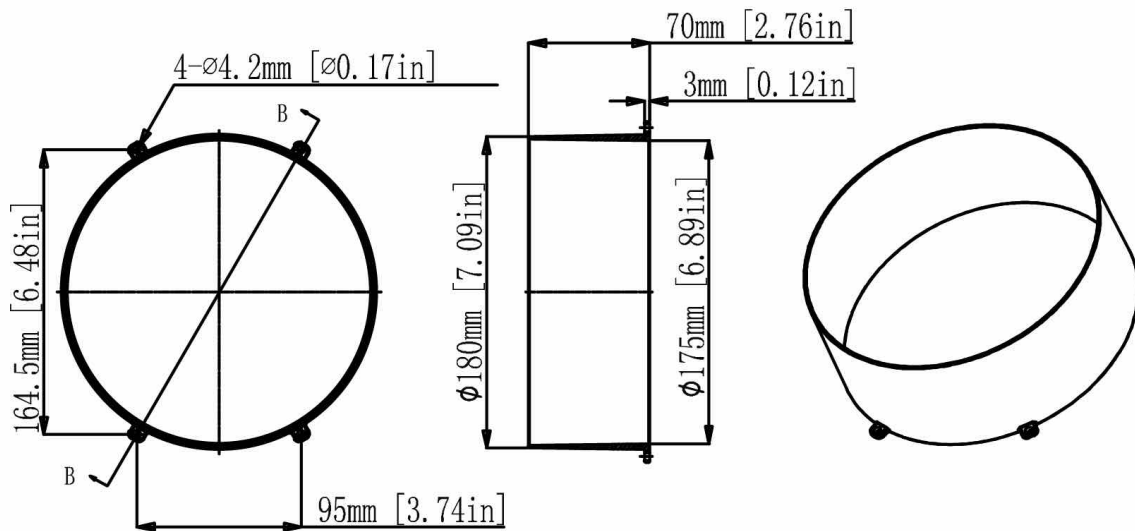
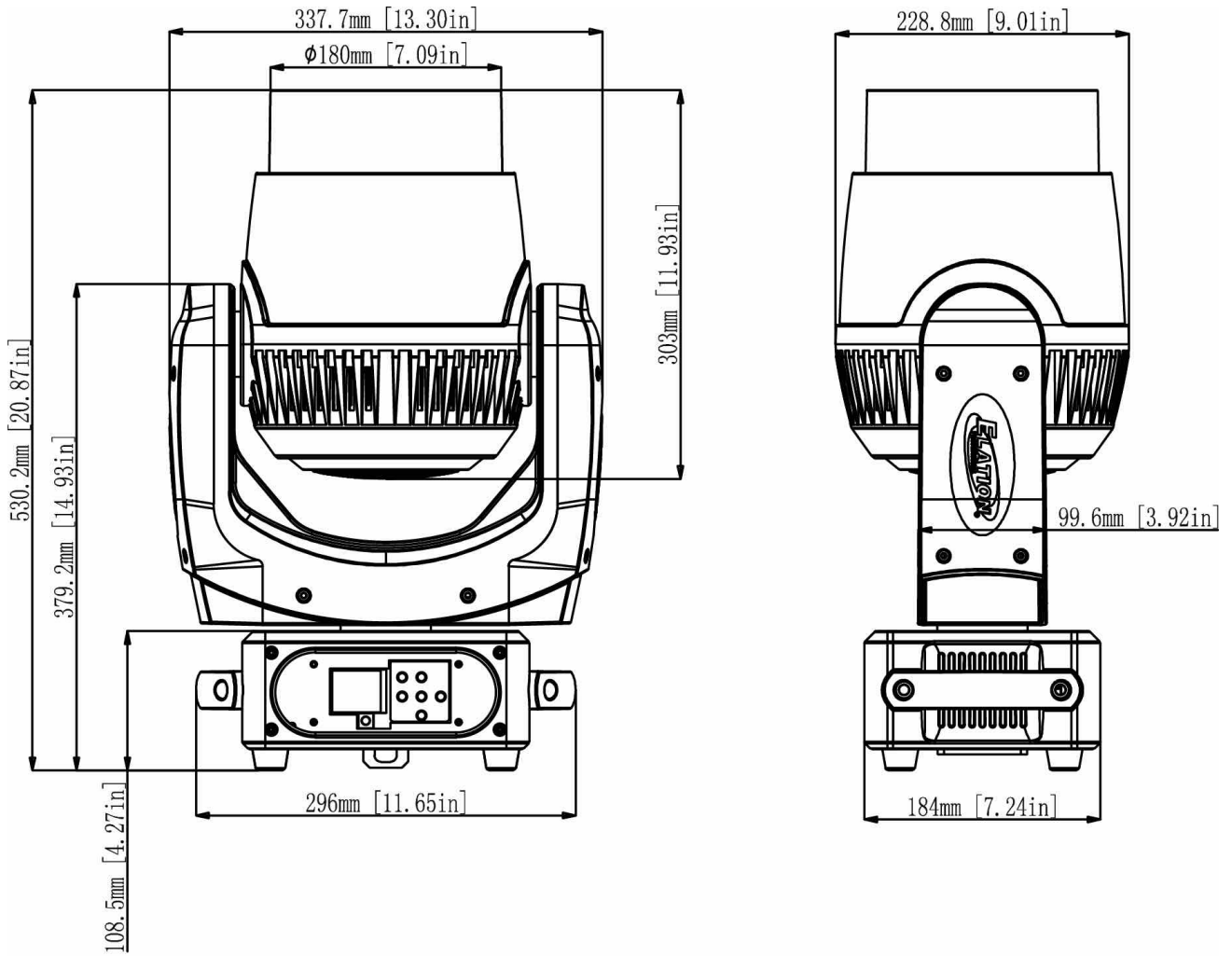

Please Note: Specifications and improvements in the design of this unit and this manual are subject to change without any prior written notice.

OPTIONAL ACCESSORIES

ORDER CODE	ITEM
FW120SNOOT	FUZE WASH 575 Snoot
TRIGGER CLAMP	Heavy Duty Wrap Around Hook Style Clamp
AC5PDMX5PRO	5 ft. (1.5m) 5pin PRO DMX Cable
NEU088	3 ft. (1m) PowerCON TRUE1 Power Link Cable
	Additional Cable Lengths Available

